



EA Series Automated True Union Ball Valves

1/2" TO 2" PVC AND CPVC

VALVE FEATURES

- Available in PVC and CPVC
- EPDM Seals
- PTFE Seats
- Full Port Design
- Fully Serviceable
- Double O-Ring Stem Seals

ACTUATOR FEATURES

- UL/CSA Listed Motor
- Thermoplastic NEMA 4 / 4X enclosure
- 2.5 Second, 90° Cycle Time
- Thermal Overload Protection
- Permanently Lubricated Gear Train
- Actuator Brake
- No Need for Manual Adjustments
- Blind Leads Connection
- Standard 120 VAC
- Unidirectional, Not Reversing

MATERIALS

- PVC Cell Class 12454 per ASTM D1784
- CPVC Cell Class 23447 per ASTM D1784
- EPDM O-Ring Seals

TECHNICAL INFORMATION

SELECTION CHART

SIZE	VALVE MATERIAL	END CONNECTION	VALVE SEALS	VALVE PRESSURE RATING
1/2" – 2" (DN15 – DN50)	PVC or CPVC	Socket and Threaded	EPDM	250 PSI @ 70°F 16 Bar @ 21°C Non-Shock

* PVC and CPVC socket ends available to ISO 727-1 and threaded ends to BS21. Not for use with "Z" Ball.

EA Series Automated True Union Ball Valves

1/2" TO 2" PVC AND CPVC

TECHNICAL INFORMATION, CONTINUED

DIMENSIONS

SIZE in / DN	1 in / mm	2 in / mm	3 in / mm	4 in / mm	5 in / mm	WEIGHT lbs / kg
1/2 / 15	4.63 / 118	2.25 / 57	8.30 / 211	4.75 / 121	4.34 / 110	6.80 / 3.08
3/4 / 20	4.75 / 121	2.63 / 67	8.46 / 215	4.75 / 121	4.34 / 110	6.80 / 3.08
1 / 25	5.25 / 133	3.00 / 76	8.73 / 222	4.75 / 121	4.34 / 110	7.10 / 3.22
1-1/4 / 32	6.30 / 160	4.00 / 102	9.50 / 241	4.75 / 121	4.34 / 110	8.00 / 3.63
1-1/2 / 40	6.75 / 171	4.00 / 102	9.15 / 232	4.75 / 121	4.34 / 110	8.10 / 3.67
2 / 50	8.00 / 203	4.75 / 121	9.65 / 245	4.75 / 121	4.34 / 110	9.80 / 4.45

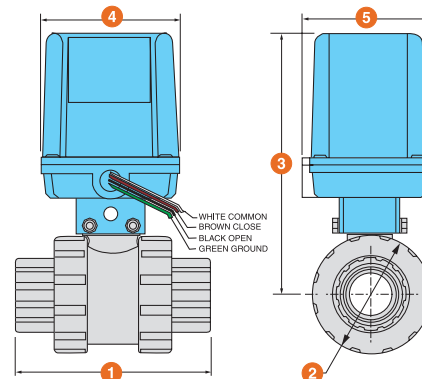

Dimensions are subject to change without notice – consult factory for installation information

ACTUATOR SPECIFICATIONS

MODEL	EA
Torque Output (in-lbs)	120
Standard Voltage	120 VAC
Duty Cycle	25%
Thermal Overload	Standard
Cycle Time (secs @ 90°)	2.5
Conduit Entry	1/2" NPT
Enclosure	NEMA 4 / 4X
Enclosure Material	Polypropylene
Max Current Amps @ 115 VAC	1.8

VALVE SPECIFICATIONS

VALVE TYPE	TRUE UNION
Material of Construction	PVC, CPVC
Seals	FPM/EPDM
Seats	PTFE
End Connections	Socket or Threaded
Sizes	1/2", 3/4", 1", 1-1/4", 1-1/2" and 2"
Pressure Rating	250 PSI @ 70°F non-shock
Design	Full Port

Cv VALUES

SIZE in / DN	Cv VALUES	SIZE in / DN	Cv VALUES
1/2 / 15	8.0	1-1/4 / 32	75.0
3/4 / 20	15.0	1-1/2 / 40	90.0
1 / 25	29.0	2 / 50	140.0

PRESSURE LOSS CALCULATION FORMULA

$$\Delta P = \left[\frac{Q}{C_v} \right]^2$$

ΔP = Pressure Drop
 Q = Flow in GPM
 C_v = Flow Coefficient



Hayward is a registered trademark
of Hayward Industries, Inc.
© 2018 Hayward Industries, Inc.

USA: 1.888.429.4635 • Fax: 1.888.778.8410 • One Hayward Industrial Drive • Clemmons, NC 27012 • Email: hfcsales@hayward.com
 Canada: 1.888.238.7665 • Fax: 1.905.829.3636 • 2880 Plymouth Drive • Oakville, ON L6H 5R4 • Email: hflowcanada@hayward.com
 Visit us at: haywardflowcontrol.com