

NEW PRODUCT PREVIEW
**SB Series
Simplex Basket Strainer**

1/2" TO 2" NATURAL PVDF

KEY FEATURES

- NEW Natural PVDF
- True Union Design
- Ergonomic Hand-Removable Cover
- In-Line or Loop Connections
- External Cover Threads
- Integral Flat Mounting Bases
- PVDF Basket Standard

OPTIONS

- Stainless Steel, Monel®, Hastelloy® and Titanium Strainer Baskets
- Pressure Differential Gauge and Switch
- Stainless Steel Baskets Available with Metal Mesh Liners

MATERIALS

- Natural PVDF per ASTM D3222 Type 1
- FPM O-Ring Seals

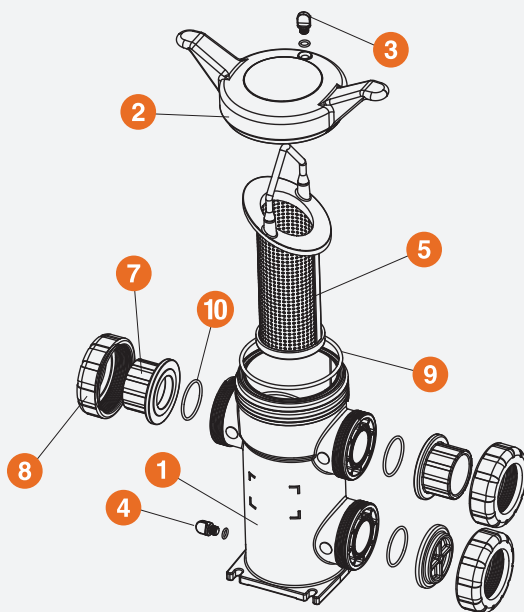
TECHNICAL INFORMATION
EXPLODED VIEW

SELECTION CHART

SIZE*	MATERIAL	END CONNECTION	SEALS	PRESSURE RATING
1/2" – 2" (DN15 – DN50)	PVDF	Socket Fusion, Threaded	FPM	150 PSI @ 70°F 10 Bar @ 21°C Non-Shock
1" – 2" (DN25 – DN50)	PVDF	Flanged	FPM	150 PSI @ 70°F 10 Bar @ 21°C Non-Shock



SB Series Simplex Basket Strainers

1/2" TO 2" NATURAL PVDF

TECHNICAL INFORMATION, CONTINUED

PARTS LIST

1. Body
2. Cover
3. Vent Plug and O-Ring
4. Drain Plug and O-Ring
5. Basket
6. Flange (Optional)*
7. End Connector
8. Nut
9. Cover O-Ring
10. End Connector O-Ring

*Only 2" available with Flanged Ends

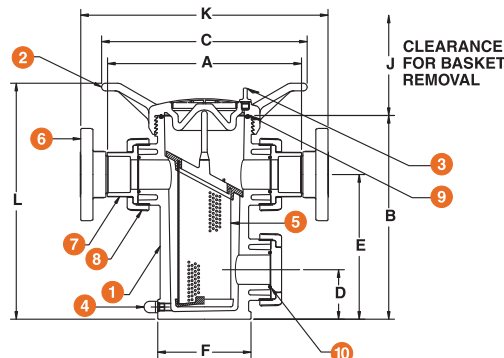

OPERATING TEMPERATURE/PRESSURE

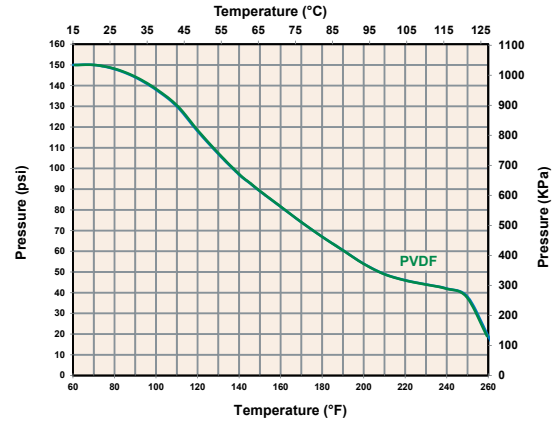

DIMENSIONS

SIZE in / DN	A in / mm	B in / mm	C in / mm	D in / mm	E in / mm	F in / mm	J in / mm	K in / mm	L in / mm	WEIGHT lbs / kg		VOLUME gal / LT
										SOC / THD	FLANGED	
1/2 / 15	8.33 / 212	9.47 / 241	10.70 / 272	2.20 / 56	6.63 / 168	4.22 / 107	8.00 / 203	-	11.63 / 295	6.50 / 2.95	-	.20 / .76
3/4 / 20	8.54 / 217	9.47 / 241	10.70 / 272	2.20 / 56	6.63 / 168	4.22 / 107	8.00 / 203	-	11.63 / 295	6.50 / 2.95	-	.20 / .76
1 / 25	8.60 / 218	9.47 / 241	10.70 / 272	2.20 / 56	6.63 / 168	4.22 / 107	8.00 / 203	11.1 / 282	11.63 / 295	6.50 / 2.95	7.5 / 3.40	.20 / .76
1-1/4 / 32	12.62 / 321	13.13 / 334	13.12 / 333	3.23 / 82	9.35 / 237	6.02 / 153	12.86 / 327	-	15.40 / 391	17.00 / 7.71	-	.70 / 2.65
1-1/2 / 40	12.53 / 318	13.13 / 334	13.12 / 333	3.23 / 82	9.35 / 237	6.02 / 153	12.86 / 327	15.53 / 394	15.40 / 391	17.00 / 7.71	19.5 / 8.85	.70 / 2.65
2 / 50	12.58 / 320	13.13 / 334	13.12 / 333	3.23 / 82	9.35 / 237	6.02 / 153	12.86 / 327	15.94 / 395	15.40 / 391	17.00 / 7.71	19.5 / 8.85	.70 / 2.65

Dimensions are subject to change without notice – consult factory for installation information

PRESSURE DROP CALCULATIONS

BASKET PERFORATION CORRECTION FACTORS

For 1/2" to 2" Strainers

Plastic		Stainless Steel	
1/32"	1.05	1/32"	.82
		20 Mesh	.79
1/16"	1.00	1/16"	.74
		40 Mesh	1.01
1/8"	.58	1/8"	.58
		60 Mesh	1.20
3/16"	.46	5/32"	.37
		80 Mesh	1.16
		3/16"	.46
		100 Mesh	1.20
		1/4"	.58
		200 Mesh	1.09
		3/8"	.45
		325 Mesh	1.22

PRESSURE LOSS CALCULATION FORMULA

The pressure drop across the strainer, for water or fluids with a similar viscosity, can be calculated using the formula at the right:

$$\Delta P = \left[\frac{Q}{C_v} \right]^2$$

ΔP = Pressure Drop

Q = Flow in GPM

C_v = Flow Coefficient

Cv VALUES

SIZE in / DN	Cv VALUES
1/2 / 15	15
3/4 / 20	18
1 / 25	20
1-1/4 / 32	55
1-1/2 / 40	58
2 / 50	60

The above Cv Values were determined using a 1 / 16" perforated plastic basket in 1/2" through 2" strainers.

To calculate pressure drop through vessels using other than 1 / 16" perforated baskets, first calculate the pressure drop using the listed Cv, and then multiply the result by the correction factor in the Correction Factors chart to the left.



Hayward is a registered trademark of Hayward Industries, Inc. © 2019 Hayward Industries, Inc.

NPP1019